

4.5-r SILT FENCE

Alternative Names: Filter Fence, Erosion Control Fence (EC Fence)

DESCRIPTION

Silt fences are temporary sediment control barriers used to intercept and detain sediment while decreasing the velocity of runoff. Silt fences usually consist of geotextile filter fabric spread along the contour and anchored into the soil. Steel or wood posts are used to support the silt fence. In many cases, a wire mesh fence is used as a back support for the silt fence.

SITE SUITABILITY

- Used for sediment control when positioned below the toe of an exposed and/or erodible slope (or placed below other small cleared areas).
- Used to prevent sediment from entering streams, channels, bodies of water, and other sensitive areas.
- Along paved surfaces adjacent to exposed and/or erodible bare soil areas.
- Placed around temporary stock piles.

Advantages

- Intercepts and captures sediment generated from surface runoff within a project area.
- Prevents sedimentation damage to adjacent properties.
- Minimizes degradation of water quality, especially when used adjacent to water courses.
- Reduces runoff velocity and therefore the erosive capacity of any concentrated runoff generated from the project area.

Disadvantages

- Even if properly maintained, the life expectancy of a silt fence is generally limited to six months to one year.
- Silt fences cannot be used in channels, streams, ditches, and other locations of concentrated flow.
- Silt fences cannot be deployed in areas subject to ponding of water.
- Silt fences must be carefully installed or they will be rendered ineffective because of undercutting, collapsing, and end cutting.
- The proper installation of silt fences requires some soil disturbance in order to entrench and anchor the filter fabric.
- Silt fences on active construction sites require frequent inspection and maintenance.

DESIGN CONSIDERATIONS

- From fabrics made of polypropylene, nylon, polyester, and ethylene yarn, select a fabric containing ultraviolet inhibitors and stabilizers, to ensure a minimum life expectancy of six months.

BMP DESIGN APPROACH	
<input type="checkbox"/>	Pollutant Source Control
<input type="checkbox"/>	Hydrologic Source Control
<input checked="" type="checkbox"/>	Stormwater Treatment
SCALE OF APPLICATION	
<input checked="" type="checkbox"/>	All SFR and MFR < 1 acre
<input checked="" type="checkbox"/>	MFR 1-5 Acre and CICU < 5 acres
<input checked="" type="checkbox"/>	MFR and CICU > 5 acres and all WQIPs
TYPE OF APPLICATION	
<input checked="" type="checkbox"/>	Temporary
<input type="checkbox"/>	Permanent

- Install silt fence systems along the contour of the slope.
- Ensure that the upslope drainage area does not exceed ¼ acre for every 100 linear feet of silt fence deployed, and that the maximum slope perpendicular to the silt fence line is no more than 1:1.
- Avoid installing long, uninterrupted runs of silt fence. Consider designing silt fence systems with running lengths of less than 200 linear feet.
- Generally, limit the height of a silt fence to 3 feet.
- Ensure that silt fence systems provide sufficient room for sediment to be deposited behind the silt fences and for sediment-removal equipment to access the deposits. The silt fence layout should allow for vehicles or other equipment to pass upslope of the silt fence to facilitate sediment removal maintenance.
- Consider redundant lines of silt fences for construction next to streams and sensitive areas.
- Ensure that support fence materials and the selected filter fabric are strong enough to withstand the expected sediment load.
- Silt fence intended to be left over winter should have wire mesh backing.

INSTALLATION

- Properly deploy all temporary BMPs, including silt fences, before construction begins.
- Before the silt fence is deployed, prepare the grade along the intended alignment to ensure proper installation. Clear brush and reshape the ground profile, if necessary.
- Space supporting joint posts every 4, but no more than 6, feet along the running length of the silt fence. Sites with higher runoff and sediment loading potential may require more closely spaced posts. Drive the supporting joint posts at least 18 inches into the ground and leave at least 3 feet of post above ground. Steel posts may be used for durability and be reused in subsequent projects.
- Considering installing a wire mesh fence to the posts before installing the filter fabric for additional stability. Silt fences intended to be left over winter should have wire mesh backing.
- Fasten the filter fabric securely to the uphill side of the supporting joint posts. Key-in and anchor 6 of the bottom 10 inches of fabric, by folding the bottom 4 inches and placing backfill over the folded portion.
- Turn the fabric uphill at the ends of the fence run, creating a “J” shape to prevent runoff from end-cutting.
- If fabric joints are necessary, splice the filter fabric at a supporting post with a 6 inch overlap, and fasten both pieces securely to the post.



This silt fence needs to be keyed into the soil properly.

INSPECTION AND MAINTENANCE

- A properly functioning silt fence does not allow water to flow around, over, and/or under the fence.
- Maintain silt fence function until all upslope areas have been permanently stabilized.
- Inspect silt fences at the end of each work day. During the rainy weather, inspect them more frequently. Maintain fences as needed.
- Remove sediment when deposits reach approximately one-third the height of the barrier. Use sediment as fill material or properly remove and dispose of off-site.
- If significant runoff or sediment deposition is anticipated, consider installing a second fence parallel to the original one for added capacity or as an alternative to removing captured sediment until project completion.



This silt fence is not functioning and needs maintenance.

Silt Fence Figure

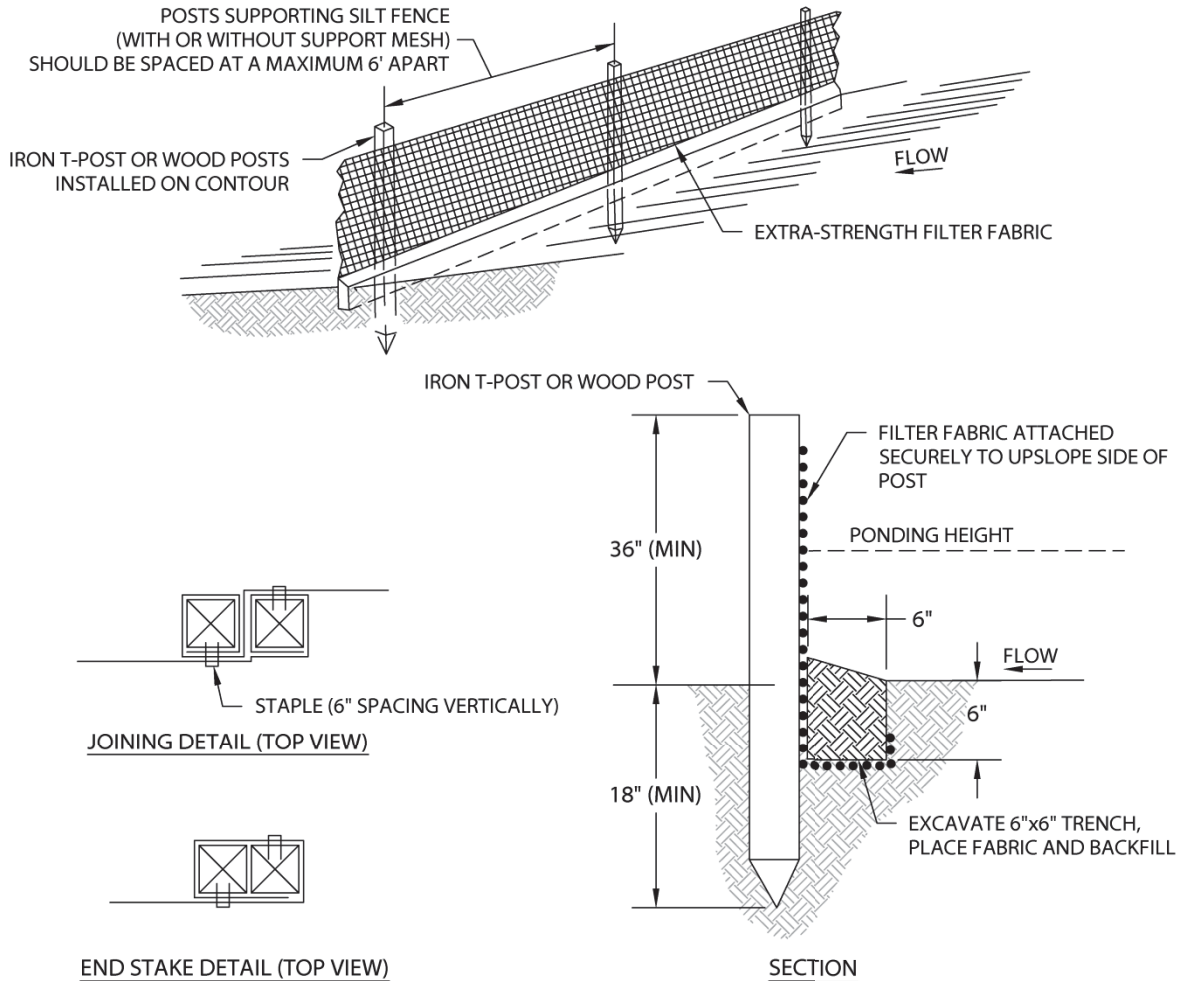

NOTES:

1. USED IN AREAS WHERE SHEET FLOW OCCURS.
2. DO NOT USE IN STREAMS, CHANNELS, OR ANYWHERE FLOW IS CONCENTRATED. DO NOT USE SILT FENCES TO DIVERT FLOW.
3. DO NOT USE BELOW SLOPES SUBJECT TO CREEP, SLUMPING, OR LANDSLIDES.
4. SILT FENCE SHOULD BE WOVEN POLYPROPYLENE WITH A MINIMUM WIDTH OF 36 INCHES AND A MINIMUM TENSILE STRENGTH OF 100 LB FORCE.
5. INSTALL ALONG A LEVEL CONTOUR SO WATER DOES NOT POND MORE THAT 1.5 FEET AT ANY POINT ALONG THE SILT FENCE.
6. THE MAXIMUM LENGTH OF SLOPE DRAINING TO ANY POINT ALONG THE SILT FENCE SHOULD BE 200 FEET OR LESS.
7. THE MAXIMUM SLOPE PERPENDICULAR TO THE FENCE LINE SHOULD BE 1:1.
8. PROVIDE SUFFICIENT ROOM FOR RUNOFF TO POND BEHIND THE FENCE AND TO ALLOW SEDIMENT REMOVAL EQUIPMENT TO PASS BETWEEN THE SILT FENCE AND TOES OF SLOPES OR OTHER OBSTRUCTIONS.
9. TURN THE ENDS OF THE FILTER FENCE UPHILL TO CREATE A "J" SHAPE, TO PREVENT STORMWATER FROM FLOWING AROUND THE FENCE.
10. LEAVE AN UNDISTURBED OR STABILIZED AREA IMMEDIATELY DOWN SLOPE FROM THE FENCE WHERE FEASIBLE.
11. SILT FENCES SHOULD REMAIN IN PLACE UNTIL THE DISTURBED AREA IS PERMANENTLY STABILIZED.
12. REMOVE SEDIMENT WHEN DEPOSITS REACH APPROXIMATELY 1/3 HEIGHT OF BARRIER.

THE TAHOE REGIONAL PLANNING AGENCY (TRPA) SHALL NOT BE RESPONSIBLE FOR THE ACCURACY OR COMPLETENESS OF ELECTRONIC COPIES OF THIS DETAIL.

Fiber Roll Silt Barrier Figure

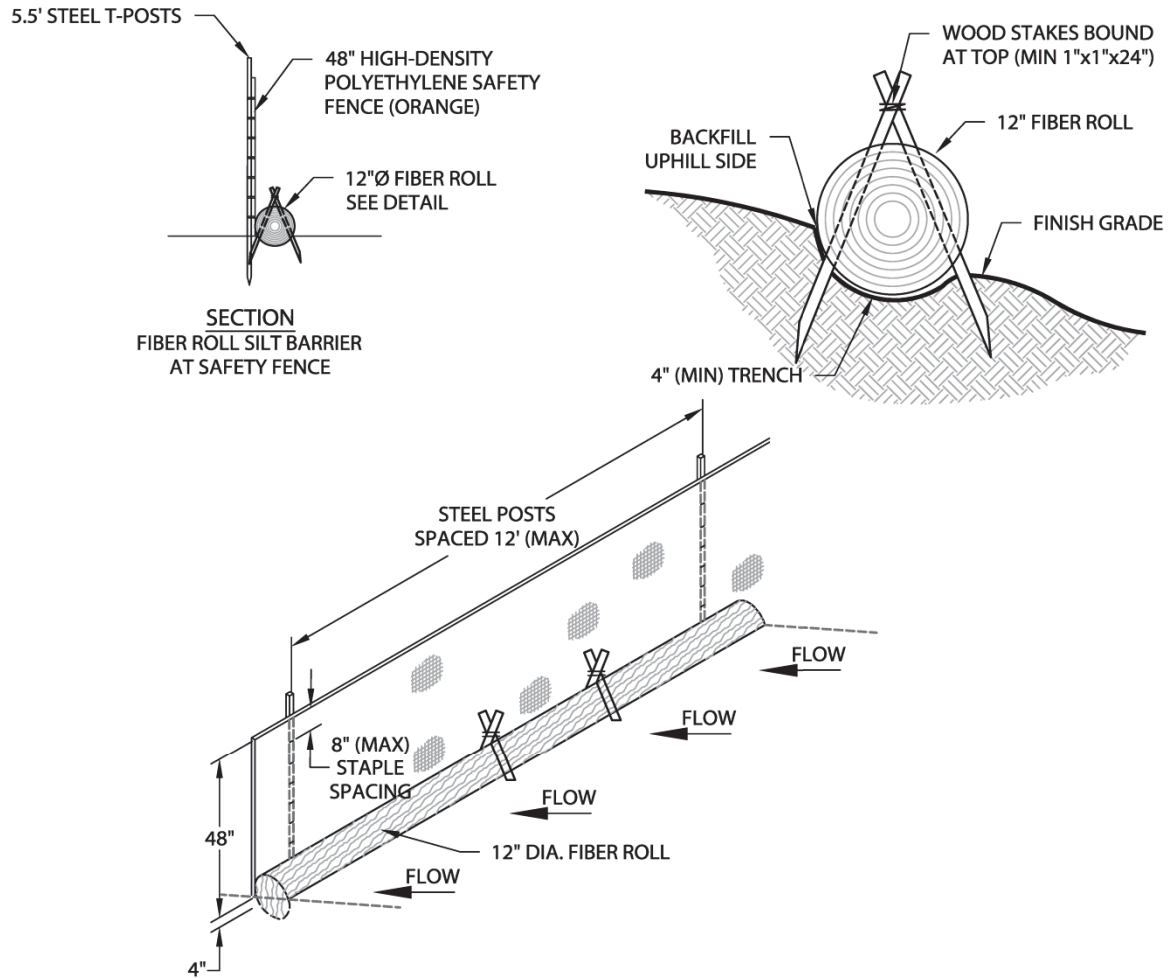

NOTES:

1. FIBER ROLL SHALL NOT BE MADE FROM STRAW. FIBER ROLLS SHALL BE BOUND BY HIGH STRENGTH COIR NETTING, AND HAVE A MINIMUM WEIGHT OF 5 LBS PER LINEAL FOOT.
2. ORANGE SAFETY FENCE IS INTENDED TO PROTECT FIBER ROLLS FROM COMPRESSION BY VEHICLES, CONSTRUCTION EQUIPMENT, ECT. FENCES SHALL BE HIGH DENSITY POLYETHYLENE WITH A MESH OPENING OF APPROXIMATELY 1 INCH BY 4 INCHES AND A MINIMUM HEIGHT OF 4 FEET. SAFETY FENCE MAY BE OMITTED IN LOW TRAFFIC AREAS.
3. FIBER ROLL SILT BARRIER SHALL BE INSTALLED ALONG CONTOUR AND ON SLOPES 5H:1V OR FLATTER UNLESS OTHERWISE APPROVED BY TRPA.
4. THE INSTALLATION CONFIGURATION SHALL PREVENT RUNOFF FROM LEAVING THE SITE OR ENTERING A WATERCOURSE WITHOUT PASSING THROUGH A SILT BARRIER.
5. THE MAXIMUM LENGTH OF SLOPE DRAINING TO THE SILT BARRIER SHALL BE 100 FEET.
6. FIBER ROLL SHALL BE INSTALLED BY SHAPING A 4 INCH DEEP FURROW TO MATCH THE SHAPE OF THE LOG, SECURING IN FURROW WITH WOOD STAKES, AND TAMPING THE GROUND AROUND THE FIBER ROLL TO FILL VOIDS BETWEEN THE LOG AND THE GROUND.

THE TAHOE REGIONAL PLANNING AGENCY (TRPA) SHALL NOT BE RESPONSIBLE FOR THE ACCURACY OR COMPLETENESS OF ELECTRONIC COPIES OF THIS DETAIL.

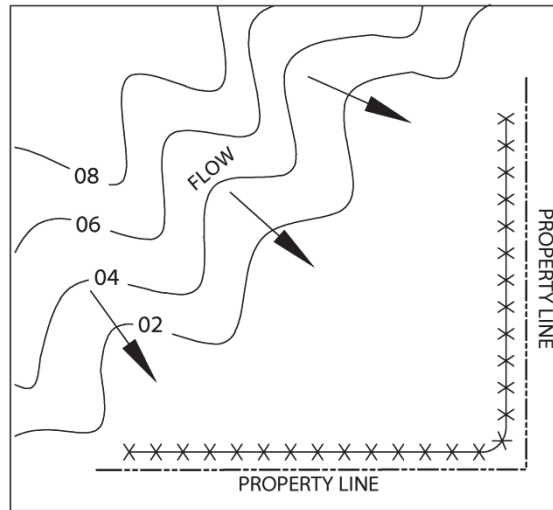

INCORRECT PLACEMENT
DO NOT LAYOUT PERIMETER CONTROL SILT FENCES ALONG PROPERTY LINES. ALL SEDIMENT-LADEN RUNOFF WILL CONCENTRATE AND OVERWHELM THE SYSTEM.

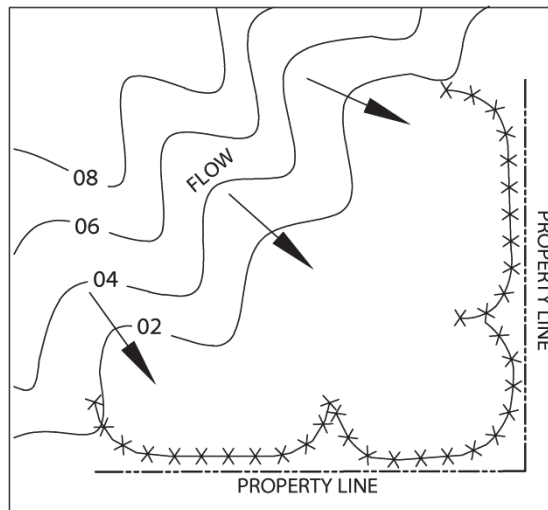

CORRECT PLACEMENT
BREAK-UP SILT FENCE INTO SECTIONS TO PREVENT SEDIMENT-LADEN RUNOFF FROM CONCENTRATING AND OVERWHELMING THE SYSTEM.

THE TAHOE REGIONAL PLANNING AGENCY (TRPA) SHALL NOT BE RESPONSIBLE FOR THE ACCURACY OR COMPLETENESS OF ELECTRONIC COPIES OF THIS DETAIL.